

**General Arrangement**

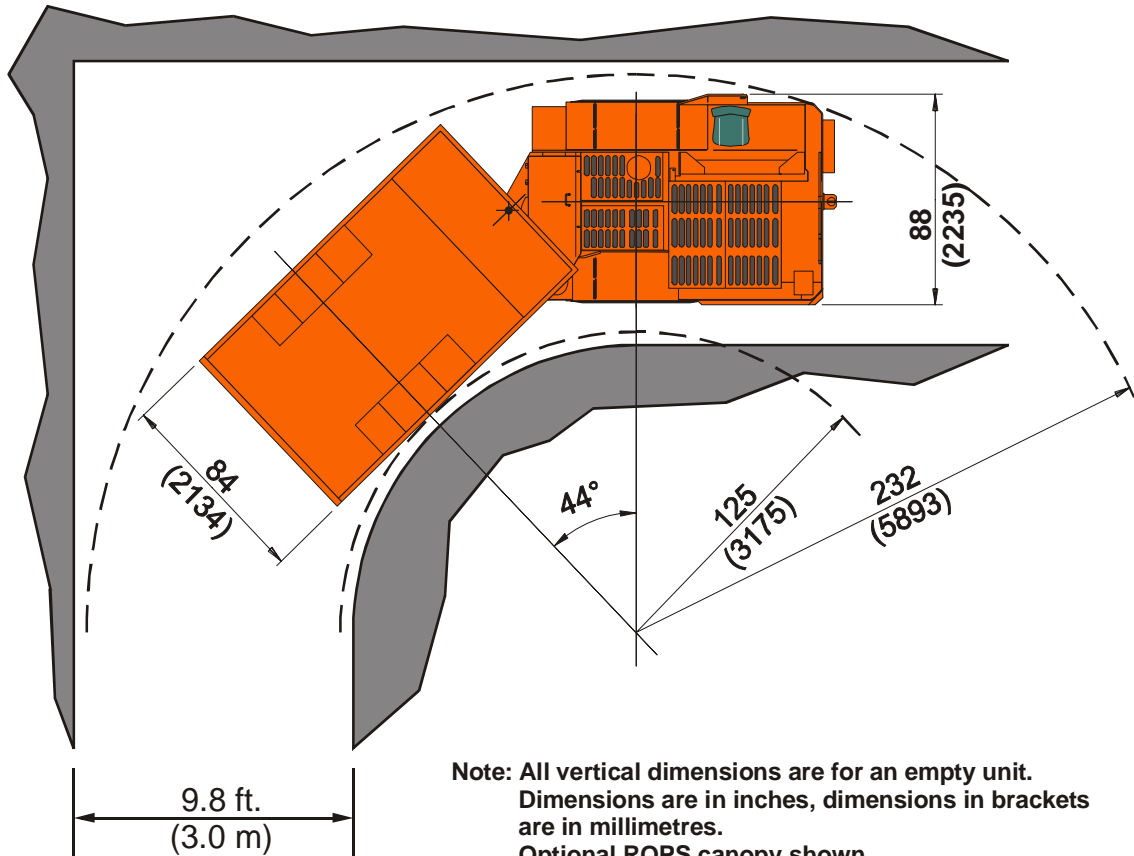
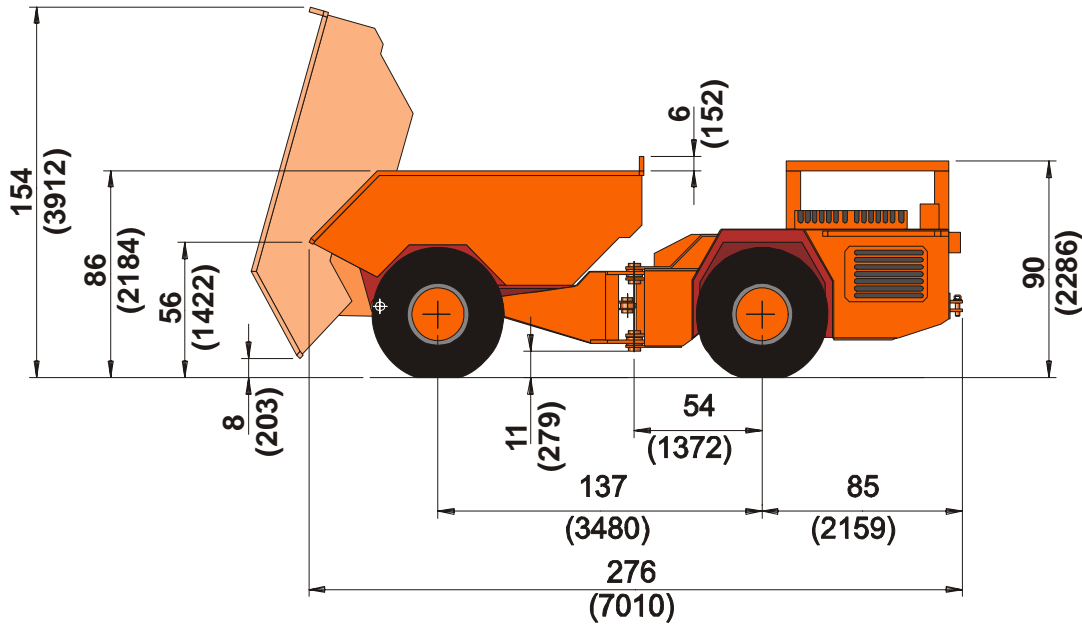

**Note: All vertical dimensions are for an empty unit.  
Dimensions are in inches, dimensions in brackets  
are in millimetres.  
Optional ROPS canopy shown.**

## Standard Unit Specifications

### General Information

#### Main Dimensions

Total length	7010 mm	276 in
Total width	2235 mm	88 in
Over all height	2286 mm	90 in
Height of dump box	2184 mm	86 in
Dump height	3912 mm	154 in

#### Operating Weights

Total	15014 kg	33100 lb.
front axle	9609 kg	21184 lb.
rear axle	5405 kg	11916 lb.

#### Loaded Weights

Total	30436 kg	67100 lb.
front axle	10653 kg	23436 lb.
rear axle	19806 kg	43664 lb.

#### Capacities

Payload	15.4 tonnes	17 tons
Box volume	8.4 m <sup>3</sup>	11.0 yd <sup>3</sup>

#### Dump Box Motion Times

Discharging time	14 sec.
Dumping angle	75 sec.

#### Driving Speeds Forward and Reverse (Loaded)

1st gear	4.7 km/h	2.9 m.p.h.
2nd gear	9.8 km/h	6.1 m.p.h.
3rd gear	16.9 km/h	10.5 m.p.h.
4th gear	29.1 km/h	18.1 m.p.h.

#### Frame

Rear and front frame	Welded steel box construction
Material	G40.21 - 50wt Cat. #3
Central hinge	full plate, clevis type with spherical bearings
Dump box	Welded steel box construction
Material	G40.21 - 50wt Cat. #3

### Power Train

#### Engine

Diesel engine	Detroit Diesel Series 40E		
Output	156 kW (210 Hp) @ 2 200 rpm		
Torque	705 Nm (520 lbf-ft) @ 1 500 rpm		
Number of cylinders	In line, 6		
Displacement	7.64 l	466 in <sup>3</sup>	
Cooling system	Liquid cooled		
Combustion principle	Turbo charged, after cooled, direct injected, 4 cycle		
Air filtration	Dry type		
Electric system	24 V		
Exhaust system	Catalytic purifier with silencer		
Fuel tank capacity	148 l	39 US gal.	

#### Transverter

Dana SOH 13.7 LMHR 32421	4 speed forward and reverse, single stage converter, 2.13:1 stall torque ratio.
--------------------------	---

#### Axles

Front	Dana SOH 16D2149, standard differential, oscillating $\pm 8^\circ$
Rear	Dana SOH 16D2149, standard differential, fixed

#### Tires

Tire size	14:00 R24		
Air pressure, front	552 kPa	5.52 bar	80 psi
Air pressure, rear	552 kPa	5.52 bar	80 psi

### Systems

#### Steering Hydraulics

Full hydraulic power steering, centre articulated with a double acting steering cylinder. Open centre system with a gear pump and pilot operated stick steer control.

**Turning Radius**

Inner	3175 mm	125 in
Outer	5893 mm	232 in
Turning angle	44 °	

**Main Components**

Hydraulic pump	Gear pump
Control valve	Pilot operated
Steering cylinder	EJC 127 mm bore X 51 mm rod (5.0" X 2.0")

**Pressure Settings**

Main relief	13.8 MPa	138 bar	2000 psi
Port relief valves	13.8 MPa	138 bar	2000 psi

**Dump Box Hydraulics**

Full hydraulic open-centre system with one gear pump. Electric push button dump box control located on the steer stick.

**Main Components**

Dump cylinder	2 stage telescopic 184/152 mm (7.25/6.0")
Hydraulic pump	Gear pump
Control valve	Pilot operated

**Pressure Settings**

Main relief	13.8 MPa	138 bar	2000 psi
Port reliefs	13.8 MPa	138 bar	2000 psi
Hyd. oil tank capacity	125 l	33 US gal.	

**Standard Brakes**

Service brakes are spring applied/hydraulically released, liquid cooled (LCB) multi-disc brakes on all wheels with two separate circuits for the front and rear axles. Service brakes also function as an emergency brake, when the emergency brake system is engaged.

**Main Components**

Pressure accumulators	Piston type with charging valve
Brake pedal valve	Modulated

**Electrical Equipment**

Alternator	24V 60 A, min
Batteries	2 x 12 V, 950 CCA
Starter	24 V, Heavy Duty
Driving lights	4pcs front, 2pcs rear

**Other Standard Equipment**

- Electric shift
- Central hydraulic pressure test points
- Central manual lubrication system
- SAE hose fittings

**Manuals**

All manuals are delivered on CD-ROM in web based format with Adobe PDF output for printing.

**Distribution**

Manual Type	Customer	Market Area
Spare parts manuals	3 Copies	1 Copy
Operator's manual	3 Copies	1 Copy
Service manual	3 Copies	1 Copy

**Optional Equipment Specifications**
**Available Alternative Equipment**

Auto lube system	Lincoln modular
------------------	-----------------

**Alternative Dump Box Options**

Volume		Width		Side Height	
6.9 m <sup>3</sup>	9.0 yd <sup>3</sup>	2134 mm	84"	1905 mm	75"
8.2 m <sup>3</sup>	10.7 yd <sup>3</sup>	2540 mm	100"	1981 mm	78"

**Available Add-On Options**

Dump box	Split dump box rework	
	Abrasion resistant box liners	
Operator's compartment	SAE ROPS canopy	
	Enclosed operator's cab with A/C (solid mounts)	
Fire suppression systems	Manual - Ansul 6 nozzles, 1 tanks	
	Automatic (Checkfire II) - Ansul 6 nozzles, 1 tanks	
Hand held fire extinguishers	4.5 kg	10 lb.
	9.1 kg	20 lb.
Emergency steering system	SAE J-1511, electric	

## Tractive Effort Curve (Metric Units)

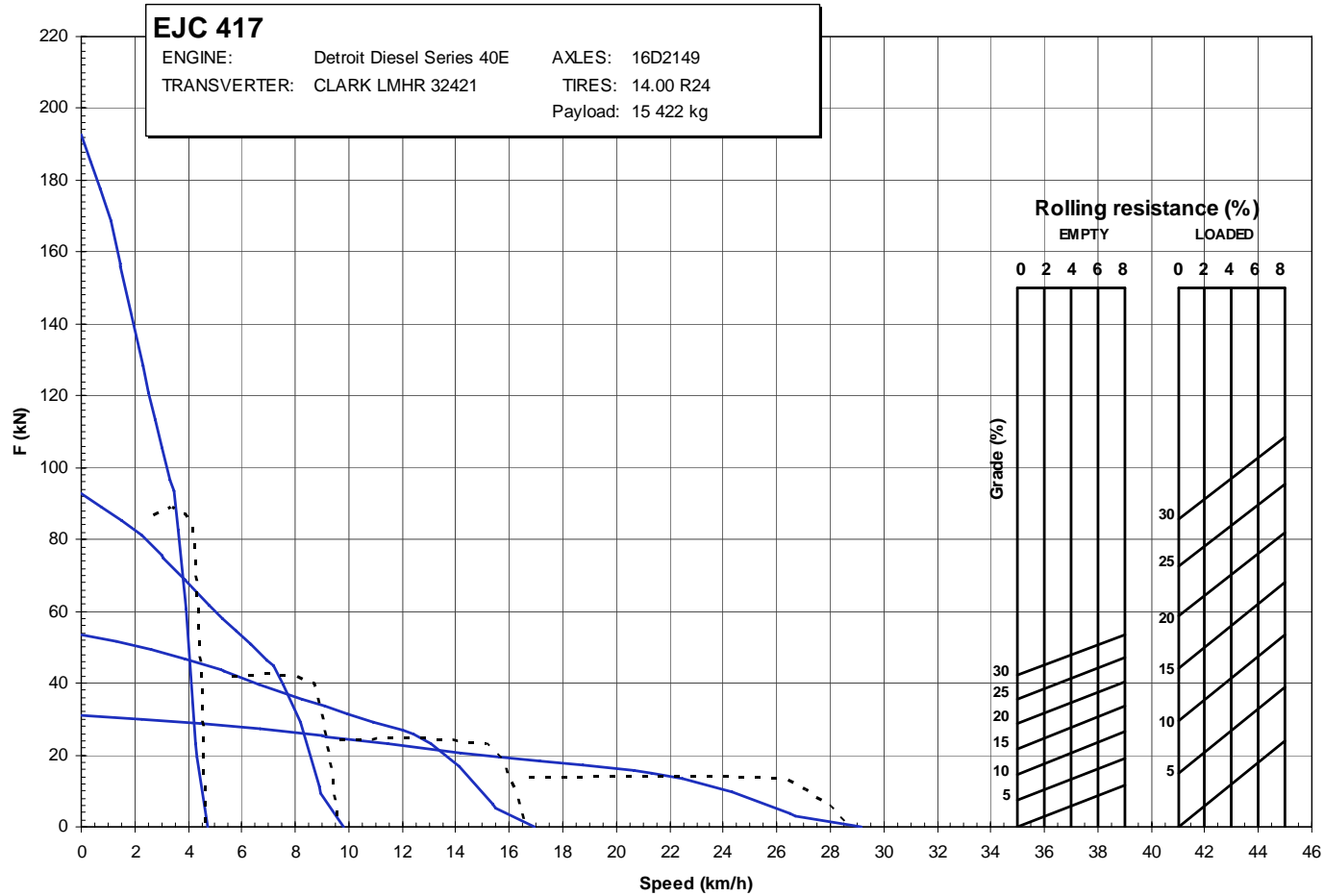

## Tractive Effort Curve (US Units)

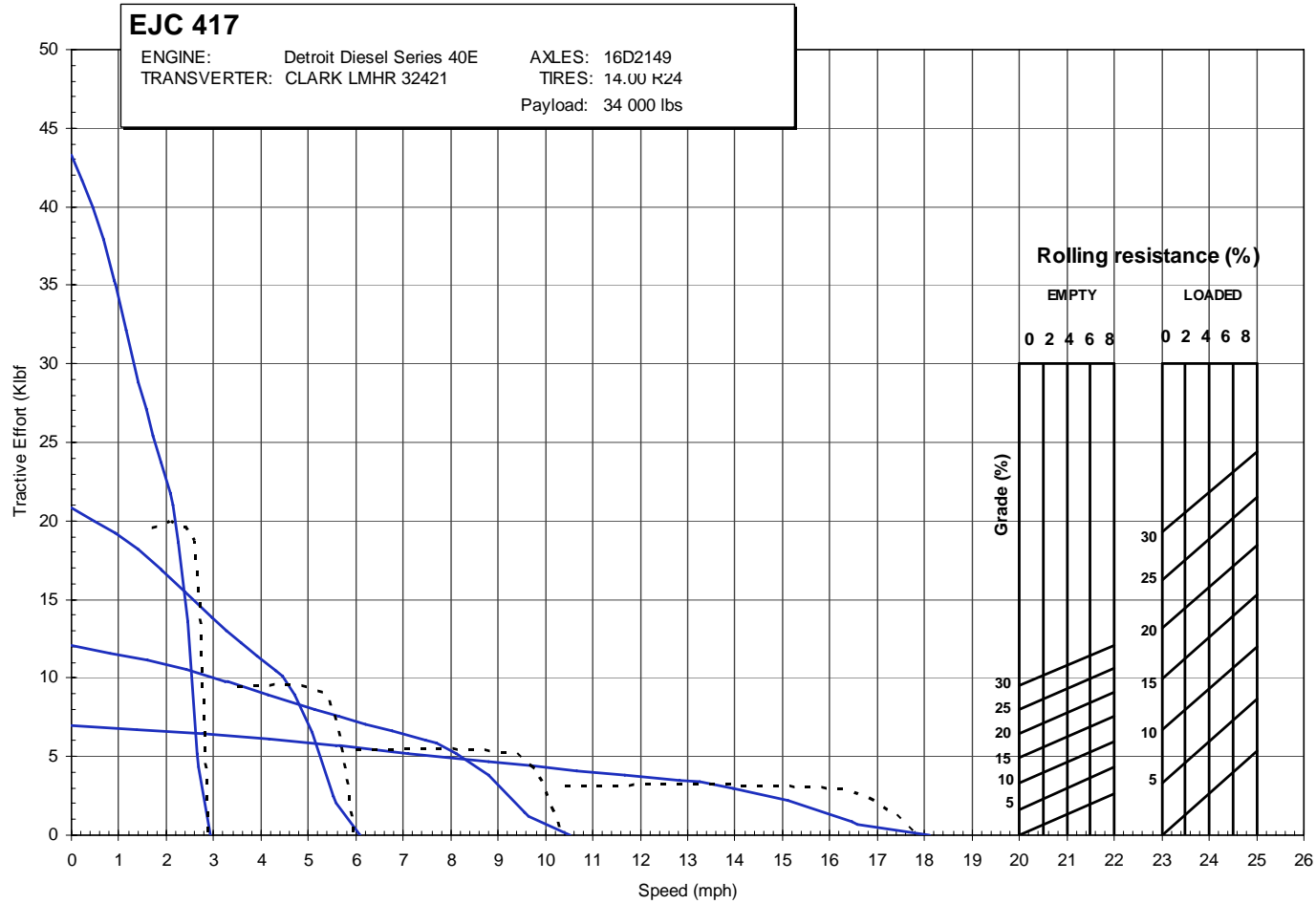

Productivity Curve (Metric Units)

EJC 417 PRODUCTIVITY

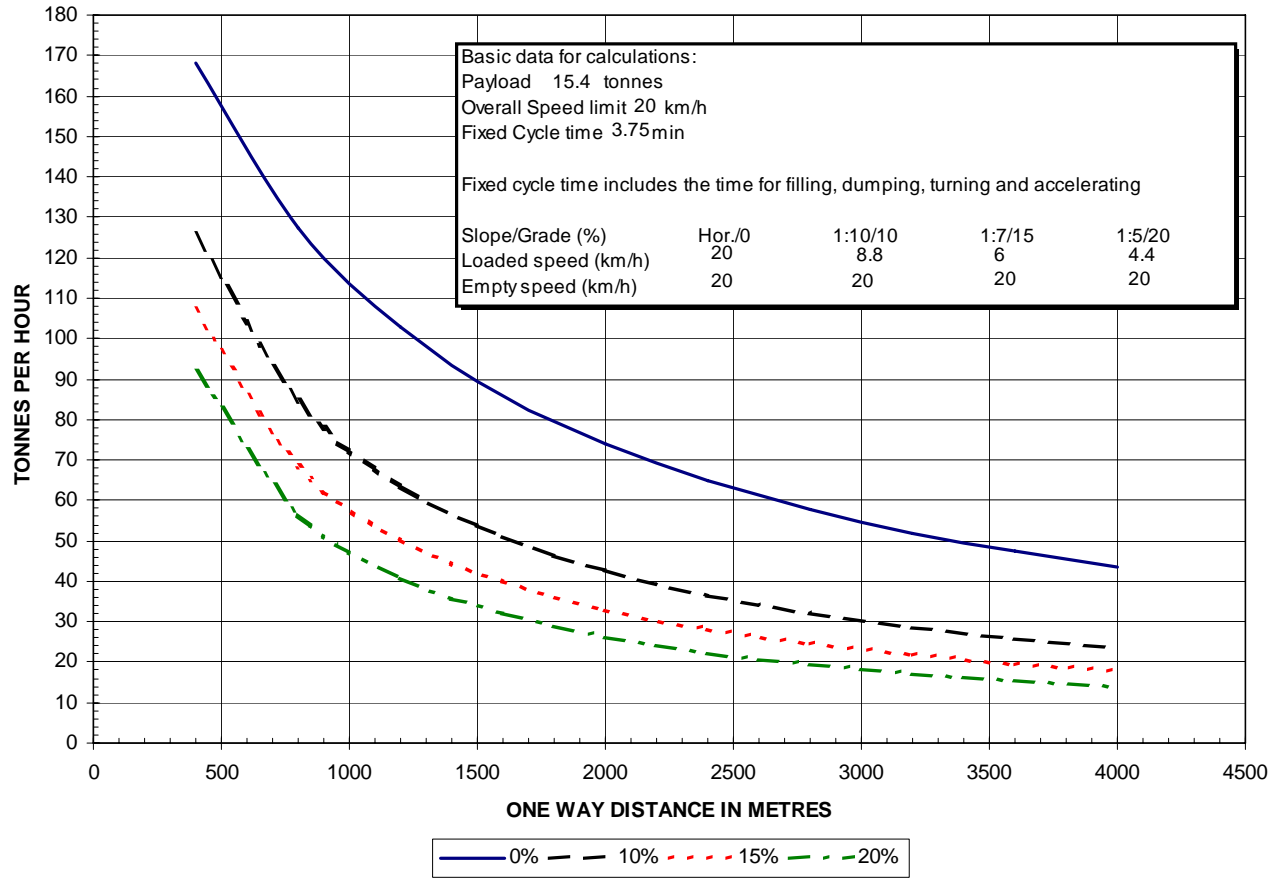

Productivity Curve (US Units)

EJC 417 PRODUCTIVITY CURVE

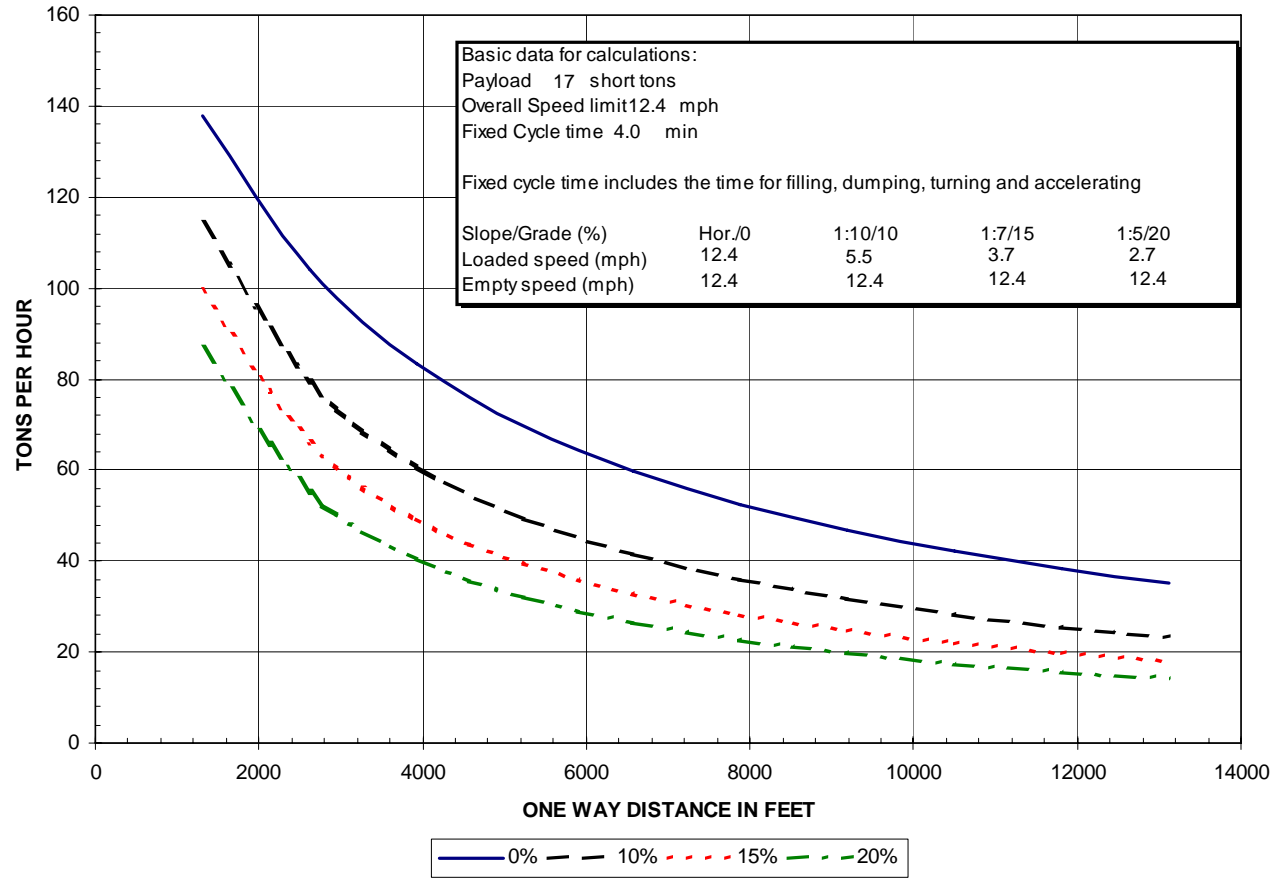

---

## End Loading with EJC 145

---

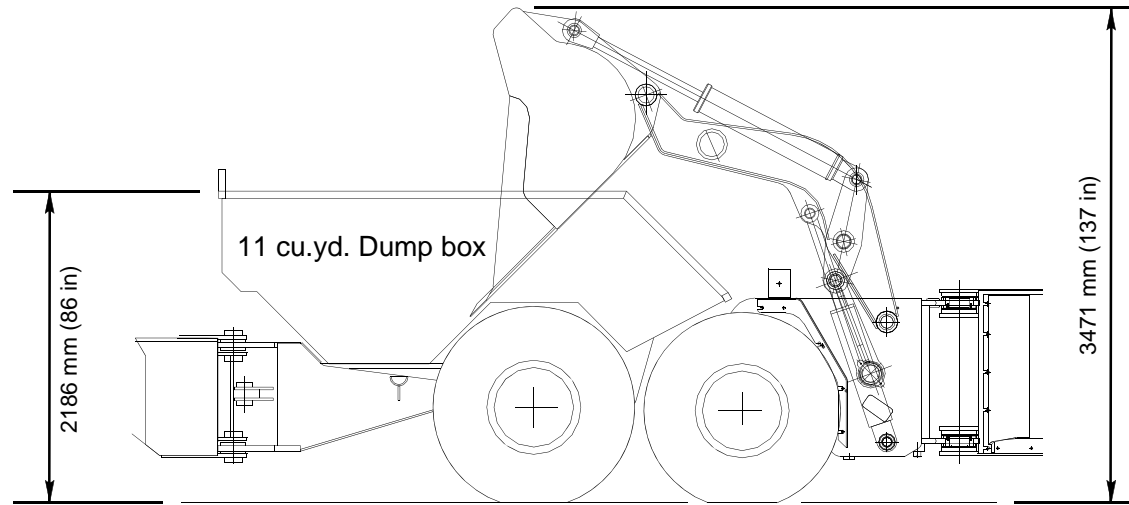

---

**Side Loading with EJC 145**

---

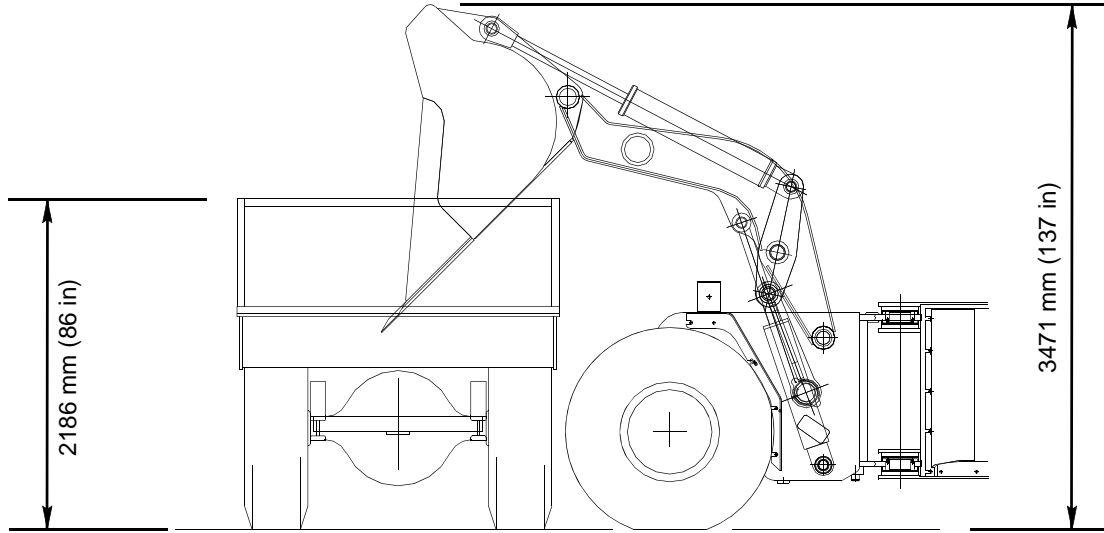

---

**End Loading with EJC 116**

---

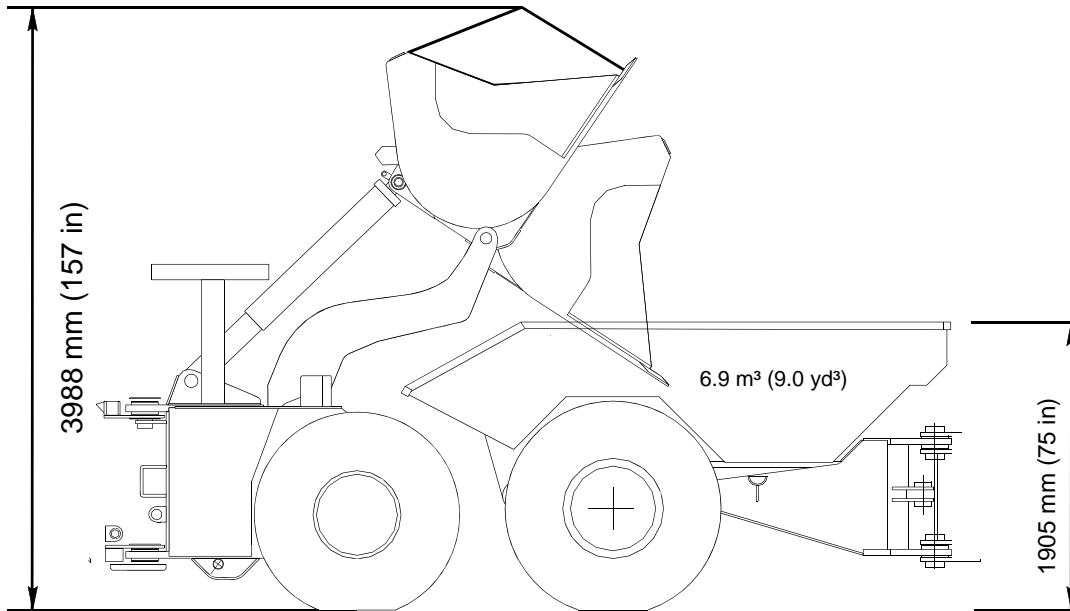

---

**Side Loading with EJC 116**

---

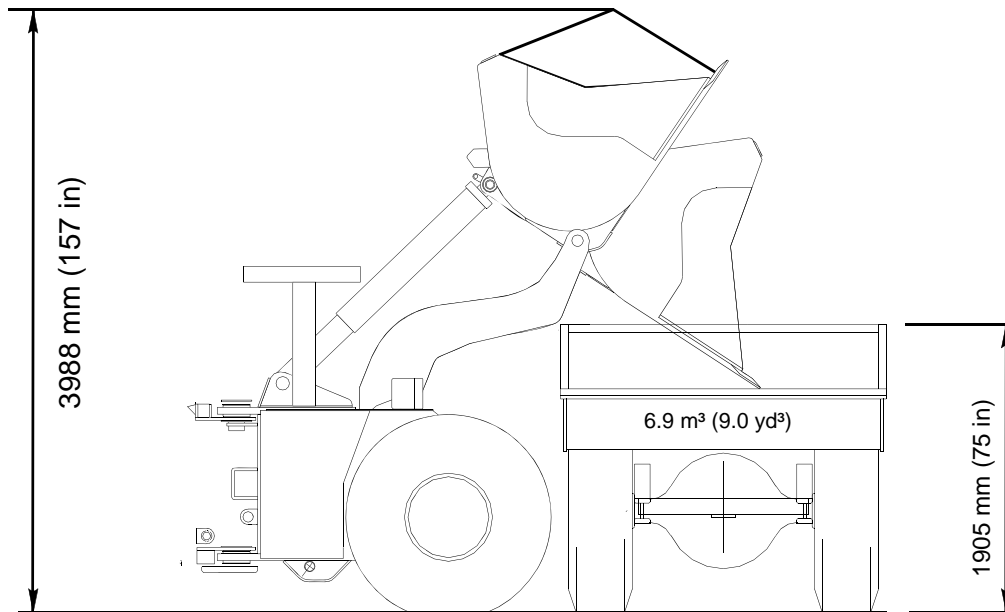

---

**End Loading with EJC 90**

---

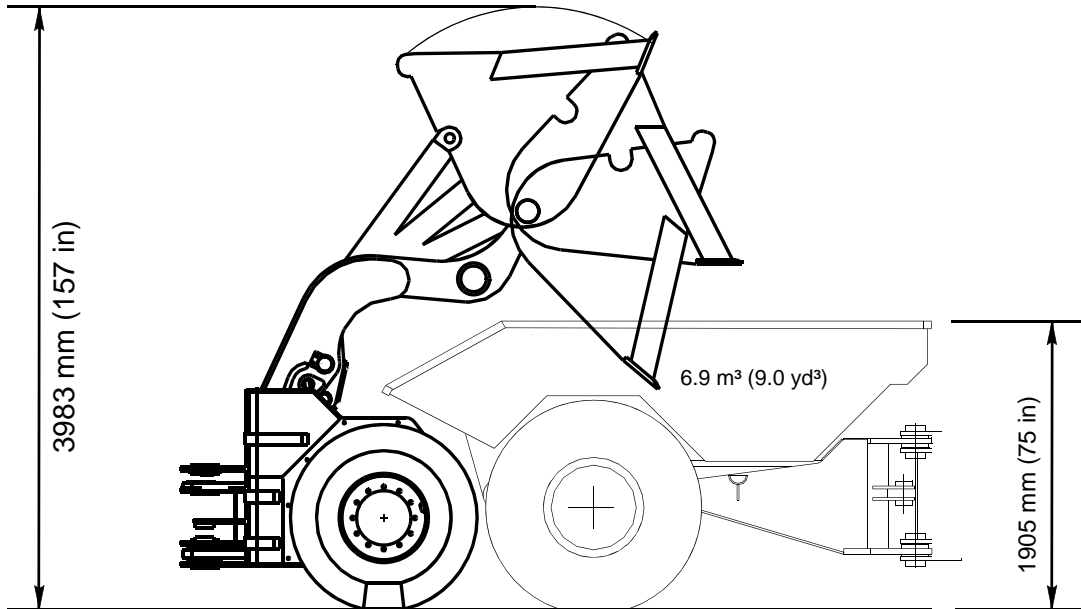

---

**Side Loading with EJC 90**

---

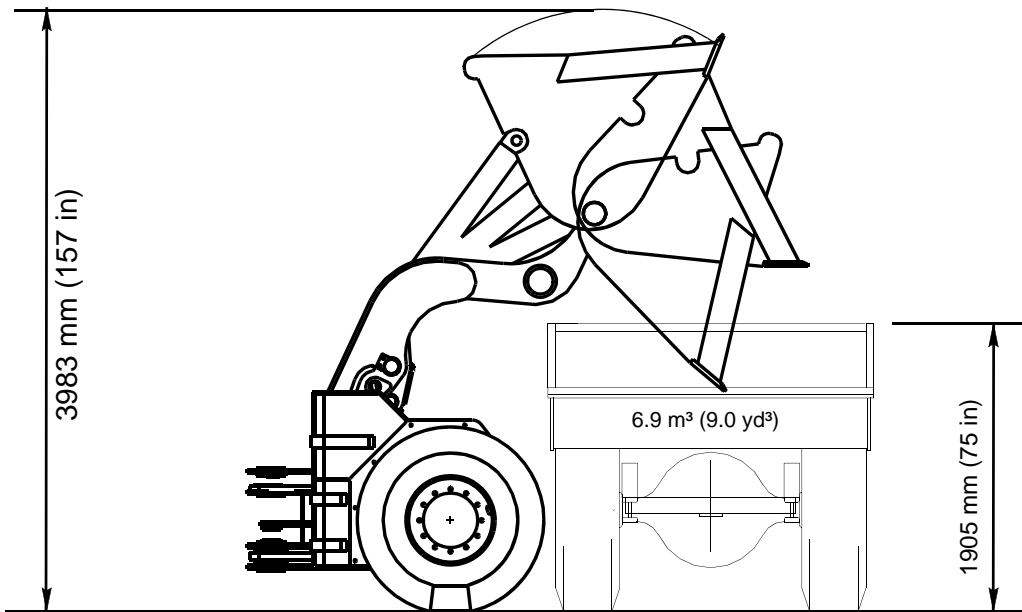

**End Loading with Toro 151**

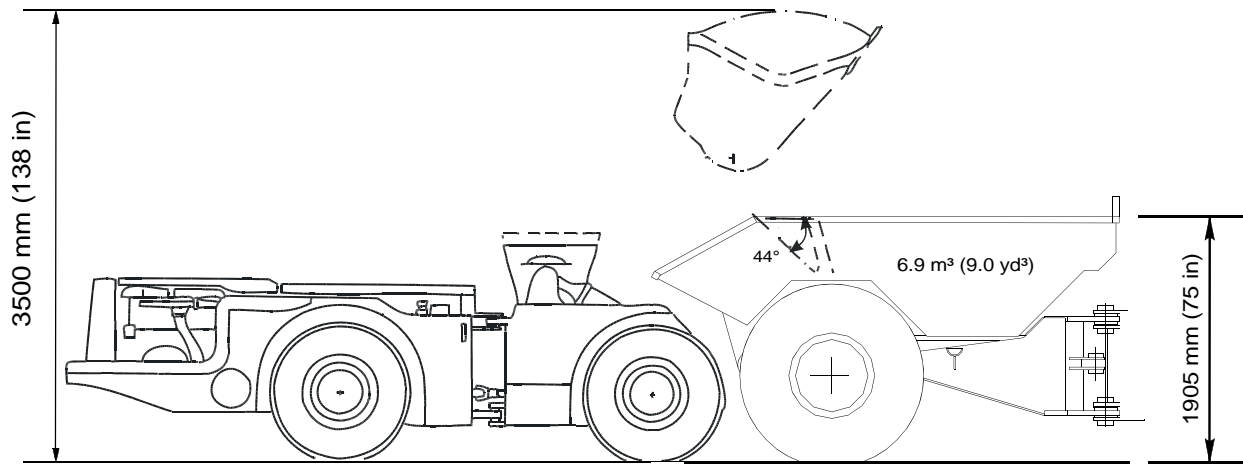

**Side Loading with Toro 151**

